

# Specification Sheet

## LB20 MS

LiFePO<sub>4</sub> – 13,2 V – 171 Wh  
high performance accumulator



Product may differ from the illustration

version: 1.0

date: 05.08.2023

# Table of content

1	Technical specifications .....	3
2	Electrical specifications .....	3
3	Features of the Battery Management System (BMS).....	4
4	Protection .....	5
4.1	Protection Modes .....	5
4.1.1	YELLOW (warning).....	5
4.1.2	RED (soft close) .....	5
4.1.3	BLACK (Instant cut off).....	5
4.2	Thresholds .....	5
5	CAN Communication & Interface .....	6
5.1	CAN Communication .....	6
5.2	Interface (DEUTSCH ASL006-05SN-HE) .....	6
6	LITE BLOX App .....	7
7	Technical drawings .....	8
7.1	Housing .....	8
7.2	Bottom plate.....	9
7.3	Battery pole adapter.....	9
8	Cell specifications (LITHIUMWERKS) .....	10
9	Certification (ISO 9001:2015) .....	11

## 1 Technical specifications

<i>Specification</i>	<i>Value</i>	<i>Annotation</i>
<b><i>Dimensions (housing only) - details see chapter <a href="#">Technical drawings</a></i></b>		
Height	106 mm	±2mm
Width	123 mm	±1mm
Length	202 mm	±1mm
Weight	21XX g	approx.
<b><i>Cell - details see chapter <a href="#">Cell specifications (LITHIUMWERKS)</a></i></b>		
Cell chemistry	LiFePO4	
Cell type	LithiumWerks	ANR26650M1B
Cell configuration	4s5p	
<b><i>Temperature</i></b>		
Temperature range for use	(- 20) – (+ 80) °C	(0) – (+ 55) °C for optimal cycle life
Temperature range for storage	(0) – (+ 40) °C	
<b><i>Other</i></b>		
Protection class conformity	IP65	

## 2 Electrical specifications

<i>Specification</i>	<i>Value</i>	<i>Annotation</i>
<b><i>Battery Pack</i></b>		
Capacity (nominal)	12,5 Ah	± 5%
Voltage (nominal)	13,2 V	
Energy	171 Wh	± 5%
Cell pack impedance	4,8 mΩ	approx.
<b><i>Charging</i></b>		
Voltage charge (maximum)	15,2 V	
Voltage charge (recommended)	14,4 V	
Current charging (recommended)	< 10 A	LiFePO4 charging device
Current charging (continuous)	< 50 A	alternator
Current charging (10s pulse)	< 100 A	alternator
<b><i>Discharging</i></b>		
Voltage discharge (minimum)	10,0 V	
Current discharging (continuous)	< 250 A	
Current discharge (10s pulse)	< 600 A	

### 3 Features of the Battery Management System (BMS)

<i>Feature</i>	<i>Description</i>	<i>Details</i>
<b>Balancing</b>	charge transfer to prevent long term cell deviation (passive)	
<b>Communication</b> (via bluetooth)	Wireless connection to an external device (smartphone/tablet) to display battery condition and status (permanent deactivation via CAN possible)	<a href="#">LITE BLOX App</a>
<b>Remote-Support</b>	Firmware updates for continuous improvement & field telemetry data evaluation via our aftersales SUPPORT TICKET system	
<b>Recording</b>	On device recording of important field telemetry in real time via App	
<b>Protection</b>	Self-protection when running outside the intended operation limits	<a href="#">Protection</a>
<b>Thresholds</b>	All thresholds can be adjusted manually via app [expert mode]	<a href="#">Thresholds</a>
<b>I.K.O.S.</b> Intelligent Kill-Operation-Switch	-smart misuse & overload protection -circuit breaker for extended sitting times without recuperation	
<b>A.V.A.T.</b> Active Vehicle Anti-Theft	will instantly shut down the full electrical load at any unauthorized starting event	
<b>CAN</b>	via DEUTSCH ASL006-05SN-HE	<a href="#">CAN Communication &amp; Interface</a>
<b>Deep discharge protection</b>	Additional deep sleep mode for cell protection. Reducing the BMS consumption current to approx. 14,2 µA below 8 V. Bluetooth/BMS is reactivation by adding external power supply.	
<b>Low self-discharge</b>	< 1mA for extended sitting time	
<b>Audiovisual feedback</b>	via beeper and LED	

## 4 Protection

### 4.1 Protection Modes

The LITE BLOX is autonomously protecting itself when leaving the intended working range (I.K.O.S. Mode). This self-protection is working on three levels:

#### 4.1.1 YELLOW (warning)

As soon as the LITE BLOX is leaving the intended operating range, the first level is active, indicated by the yellow coloured values of the corresponding parameters in the App

→ no additional operation needed

#### 4.1.2 RED (soft close)

When the LITE BLOX has left the intended operating range, the second level is active, indicated by the red coloured values of the corresponding values. An automatic deactivation takes place as soon as the BMS switches its operational mode from active to standby. The conditions mandatory for this switch are a current less than 1 A (charge or discharge) and no active Bluetooth connection for at least 60 seconds

→ press 'Reset Error' button to reactivate and contact customer service afterwards

#### 4.1.3 BLACK (Instant cut off)

When being used outside the intended operating range lithium cells may face permanent damage or internal cell failure which can result in outgassing or fire. Therefore, an instant cut off function (deactivation) is implemented, which is active as soon as the operating parameters of the LITE BLOX are critical. The instant deactivation on this level is performed without any delay (in comparison to soft close level 2)

→ please contact customer service immediately!

### 4.2 Thresholds

The following protection limits are implemented for events that would damage the battery cells  
→ do not adjust these without validation & make sure that the LITE BLOX is operated within the specified working range at any time

<i>Protection mechanism</i>	<i>YELLOW</i>	<i>RED</i>	<i>BLACK</i>
Overvoltage (cell/pack)	3,85 V / 15,4 V	3,9 V / 15,6 V	4 V / 16 V
Undervoltage (cell/pack)	3,15 V / 12,6 V	3,1 V / 12,4 V	2,5 V / 10 V
Short circuit current	-	-	900 A
Maximum charge current	-	-	220 A
Maximum temperature	80 °C	85 °C	90 °C

## 5 CAN Communication & Interface

### 5.1 CAN Communication

- Only active if data send on 0X300
- CAN Baud Rate = 1Mbaud
- No termination of CAN inside the battery
- dbc file can be provided by request

ECU2BMS		ID=0X300 / calibrate		Freq. = 20ms (50Hz)
Bits	Size	Gain	Engineering Range	Description
[0]	1	1	[0 – 1]	Charge override
[1]	1	1	[0 – 1]	BT On
[2]	1	1	[0 – 1]	BT Off
[3]	1	1	[0 – 1]	Disable Crash
[4]	1	1	[0 – 1]	Reset Killswitch
BMS2ECU1		ID=0X301 / calibrate		Freq. = 20ms (50Hz)
Bits	Size	Gain	Engineering Range	Description
[0 - 11]	12	0.001	[0 – 4.095] V	Voltage cell 1
[12 - 23]	12	0.001	[0 – 4.095] V	Voltage cell 2
[24 - 35]	12	0.001	[0 – 4.095] V	Voltage cell 3
[36 - 47]	12	0.001	[0 – 4.095] V	Voltage cell 4
[48 - 63]	16	0.001	[0 – 65.535] V	Voltage Pack 14V
BMS2ECU2		ID=0X302 / calibrate		Freq. = 20ms (50Hz)
Bits	Size	Gain	Engineering Range	Description
[0-3]	4	-	-	Alive Counter
[4]	1	1	[0-1]	Warnlevel 1
[5]	1	1	[0-1]	Warnlevel 2
[6]	1	1	[0-1]	Warnlevel 3
[7]	1	1	[0-1]	Killswitch
[8 - 15]	8	0.5	[0-100] %	SOC
[16 - 31]	16	0.1	[-3276.7 – 3276.8] A	Current Pack
[32 - 38]	8	10	[0 – 2550] A	Max Current Charge
[40 - 46]	8	10	[0 – 2550] A	Min Current Discharge
[48 – 52]	5	1	[0-31]	Error flags
[53]	1	1	[0-1]	DischargeOff
[54]	1	1	[0-1]	ChargeOff
[56 – 63]	8	1	[-40-215] C	Temperature

### 5.2 Interface (DEUTSCH ASL006-05SN-HE)

<i>PIN</i>	<i>Assignment</i>	<i>description</i>	<i>illustration</i>
1	Killswitch input	Enables the LITE BLOX when connected to ground	
2	Killswitch output	Transmits 12 Volt signal to shut down ECU, in disabled-state	
3	CAN high	CAN-communication	
4	CAN low	CAN-communication	
5	VBat +	VBat +; max 200mA, please do not use without a fuse	

## 6 LITE BLOX App



Every LITE BLOX unit comes with an innovative interface for wireless operation via smartphone or tablet (bluetooth).

In addition to the remote shutdown (I.K.O.S.) plus the integrated vehicle anti-theft (A.V.A.T.), all relevant telemetry data can be monitored in real time and sent to us for evaluation.

Telemetry data:

Search: f300-lb20 Name ▾

ID	Device Name	Serial ADoc	Date	Time
293451	#f300-lb20xx	97	22.3.2023	15:15:24
292031	#f300-lb20xx	97	19.3.2023	10:53:49
290265	#f300-lb20xx	97	15.3.2023	15:36:29
288916	#f300-lb20xx	97	11.3.2023	17:21:44
288875	#f300-lb20xx	97	11.3.2023	16:21:42
288874	#f300-lb20xx	97	11.3.2023	16:21:07
288871	#f300-lb20xx	97	11.3.2023	16:18:40
288870	#f300-lb20xx	97	11.3.2023	16:18:17

Device			
Device Name	#f300-lb20xx	Serial Akkudoc	97
Revision No.	0	FW Version	35
FW Variation	0	Password	123456
AVAT	true	IKOS	false
SOC	32%	State	ok
Reason			
Current			
	NOW	MIN	MAX
U cell1	3.29 V	1.5 V	3.81 V
U cell2	3.29 V	1.53 V	3.82 V
U cell4	3.29 V	1.5 V	3.82 V
U cell6	3.29 V	1.54 V	3.82 V
U total	13.24 V	6.11 V	15.38 V
T cells	10.21 °C	3.76 °C	42.1 °C
T pws	10.06 °C	3.65 °C	39.73 °C
I total	0.08 A	-143.99 A	717.55 A

Lifecycle	
Lifecycle start (0h)	7.7.2020 01:06:34
At Cycle	23396.59 hours
time since boot	984.48 days
time awake	329.55 hours
deep discharge	4 days
Customer N° x	
Customer Info	Vehicle
Customer message	

History			
Time	Status	Reason	Value
15.3.2023, 07:59:32	ok		0
15.3.2023, 07:56:19	disabled	user off	1
15.3.2023, 07:54:56	ok		0
11.3.2023, 12:59:39	disabled	user off	1
11.3.2023, 12:57:44	ok		0
7.3.2023, 15:08:22	disabled	user off	1
13.7.2022	ok		0
Selftest			
bmsCellOv			✓
bmsCellUv			✓
bmsCbOpen			✓
bmsCbShort			✓
bmsOt			✓
bmsUt			✓
bmsFault1			✓
bmsFault2a			✓
bmsFault2b			✓
cellUv			✓
...			-

The app will be provided via email by our engineering along with a SUPPORT TICKET for each unit.

## 7 Technical drawings

### 7.1 Housing

CAD-model can be provided by request

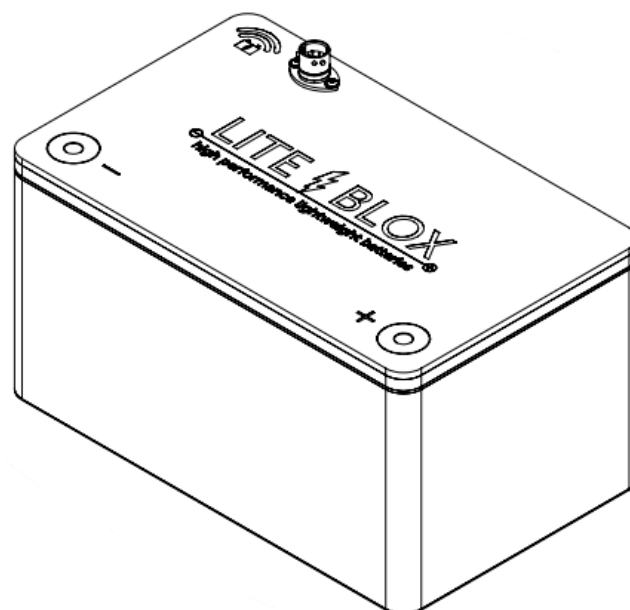
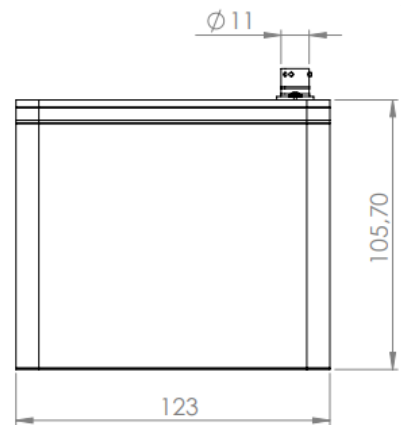
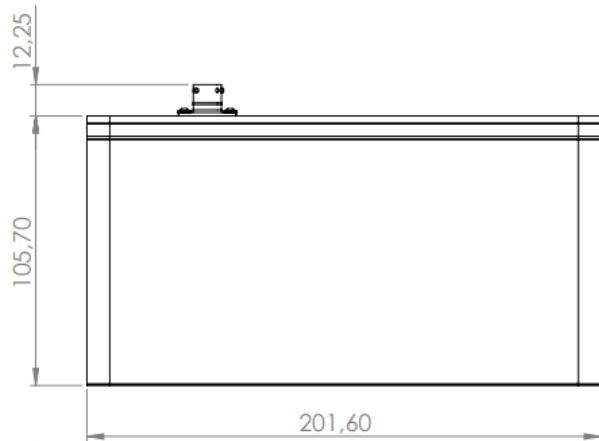
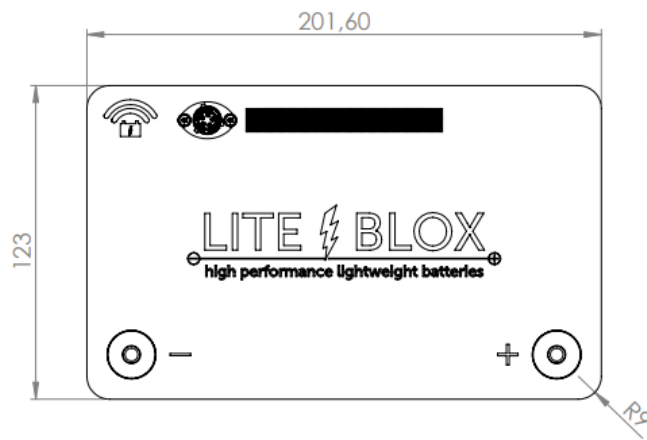



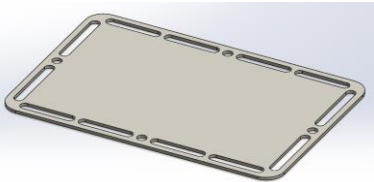
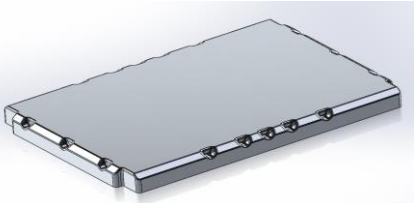

## 7.2 Bottom plate

The bottom plate is irreversibly attached to the battery

<i>Type (material)</i>	<i>Figure</i>	<i>Dimensions L x W x H</i>		
Universal CF (carbon fibre)		235 mm	156 mm	2,5 mm
LN2/H5 (aluminum)  DIN EN 50342 2		242 mm	175 mm	14 mm

## 7.3 Battery pole adapter

<i>Type (material)</i>	<i>Figure</i>	<i>Dimensions</i>			<i>torque</i>
Battery pole terminals  SAE M6 (aluminum)  DIN EN 50342 2		pole	Ø	height/ length	10 Nm
		+	19,5 mm	18 mm	
		-	17,9 mm	18 mm	
M6 mounting struts (brass)  DIN 551			M6	20	finger-tight

## 8 Cell specifications (LITHIUMWERKS)

### Specs for ANR26650M1B

#### Nominal Ratings

Voltage	3.3 V
Capacity @ 25 °C Typ (Min)	2.6 Ah (2.5)
Energy @ 25 °C	8.25 Wh
Specific Power @ 25 °C, 2 sec pulse	> 4000 W/kg
Impedance (1KHz AC) Typ	6 mΩ
Cycle Life at 1C/1C, 100% DOD	> 4000 cycles

#### Discharging

Max Continuous Discharge Current	50 A
Max Pulse Discharge Current (10s)	120 A
Minimum Voltage / HPPC Pulse	2 V / 1.6 V
Temperature	-30 °C to 55 °C

#### Charging

Recommended Charge Current	3 A
Max Continuous Charge Current	10 A
Max Pulse Charge Current (10s)	20 A
Float Voltage	3.45 V
Recommended charge V & Cut-off Current	3.6 V, taper to 125mA
Temperature Range (reduce charging current to 250mA when under 0 °C)	0 °C to 55 °C

#### Storage

Storage Temperature	-40 °C to 60 °C
---------------------	-----------------

#### Mechanical

Diameter	Ø25.96 +/- 0.5 mm
Length	65.15 +/- 0.5 mm
Mass	76 g +/- 1.0 g

#### Certifications

Transportation	UN 3480 (UN38.3), CIQ
Safety	UL 1642, IEC 62133-2

#### Transportation

Shipping	Via Air @ 30% SOC Via Sea @ 50% SOC
----------	--

Part Number 300732-006

### Cell Data

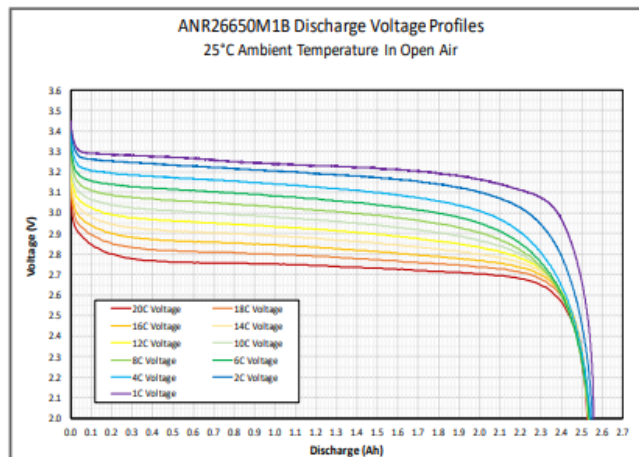
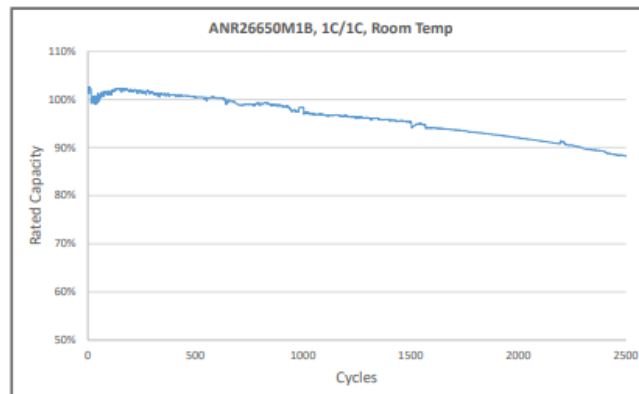

### Abuse

Nail penetration	Pass - EUCAR4
Over-Discharge	Pass - EUCAR3
Thermal Stability	Pass - EUCAR4
External Short	Pass - EUCAR3
Crush	Pass - EUCAR3
Overcharge	Pass - EUCAR2
Vent Open Pressure	1.0 - 2.0 MPa

## 9 Certification (ISO 9001:2015)



### **LITEWERKS GmbH**

**Robert-Bosch-Str. 10, D-78467 Konstanz**

wurde durch DSR-CERTIFICATION auditiert und es wird bestätigt, dass das  
Qualitäts-Management-System den Erfordernissen der

*is audited by DSR Certification and applied that the Quality Management System meets the requirements of*

# ISO 9001:2015

für den nachfolgenden Umfang entspricht:  
*standard for the following activities:*

**Entwicklung, Herstellung und Vertrieb von Akkumulatoren**  
*Development, Production and Distribution of Accumulators*

**Zertifikats-Nr.:/Certificate No: QMS-23.02.372**