

Instruction Manual

Nova-100 Battery Charger

LiFePO4 battery packs, waterproof

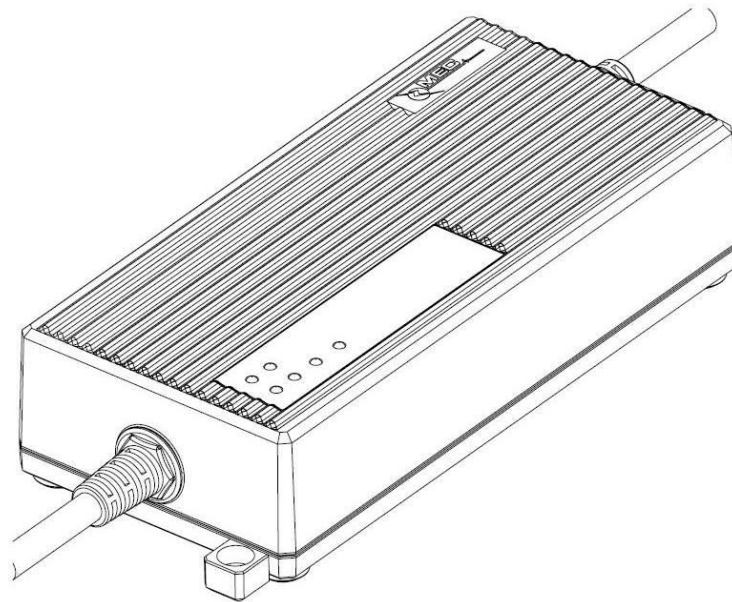

Version¹⁾

MEC Art.-Nr.

14.55V / 7A 126-04702-430IS-1720 (4 Cells)

¹⁾ V= charge termination voltage | A= max. charging current



Dear Customer!

Thank you very much for your trust in us and our product. Please read these operating instructions carefully **before** start of operation.

MEC-Energietechnik GmbH

1. Safety Rules and General Warnings



- Persons, which are not able to use the device in a safe way, because of their physical, sensory or mental competence, or because of their inexperience, should not use the charger without control or instruction of a skilled person.

- 100-240 Volts alternating current, device is not suitable for children – Danger of life!!!

- Ensure for enough air ventilation while charging!

- The charger is exclusively designed for rechargeable Li-Ion and Li-Po batteries and must not be used for other purposes.

- Please consider the charging instructions from the battery manufacturer before charging!



- Do not open! Repair work must only be accomplished by authorized companies or specialized technical staff.

- If the mains connection of the device is damaged, it must be replaced with an original wire which is available at the manufacturer or customer service.

- Never place the device on top of the battery while charging!

- Protect against direct solar radiation and temperatures over 40°C.

- In case of obvious damage or malfunction disconnect the device from mains supply and protect against unintended reconnection.



- The DC cable must not be cut or shortened.

2. General Information

This microprocessor based waterproof Lithium-Based Battery Charger was especially developed for the outdoor use and for situations where water may be present. It can be used to charge any Lithium- based battery. With the 4-step charging program the battery will be charged safely in a fully automatic mode. The output of the charger is electronically protected against short circuit. The charger is able to recover deep-discharged batteries.

The integrated metal hook allows fixing the charger in different ways. Coloured LED's on the top case are used to indicate charging status and errors.

3. Special Features

- Convection cooled IP68 housing
- Short circuit protection
- High frequent switching technology
- LED's to indicate operation and charging status
- 4-Step charging technology with automatically restart charging
- Safety charging with reduced charging current
- Indicating a non-chargeable ('dead battery') condition

4. Product Figure

1 DC-output cable
2 Green Mains-LED
3 Red Error-LED

4 Yellow Charge LED
5 Green Full-LED
6 AC-cable

7 Extractable hook
8 Wall brackets

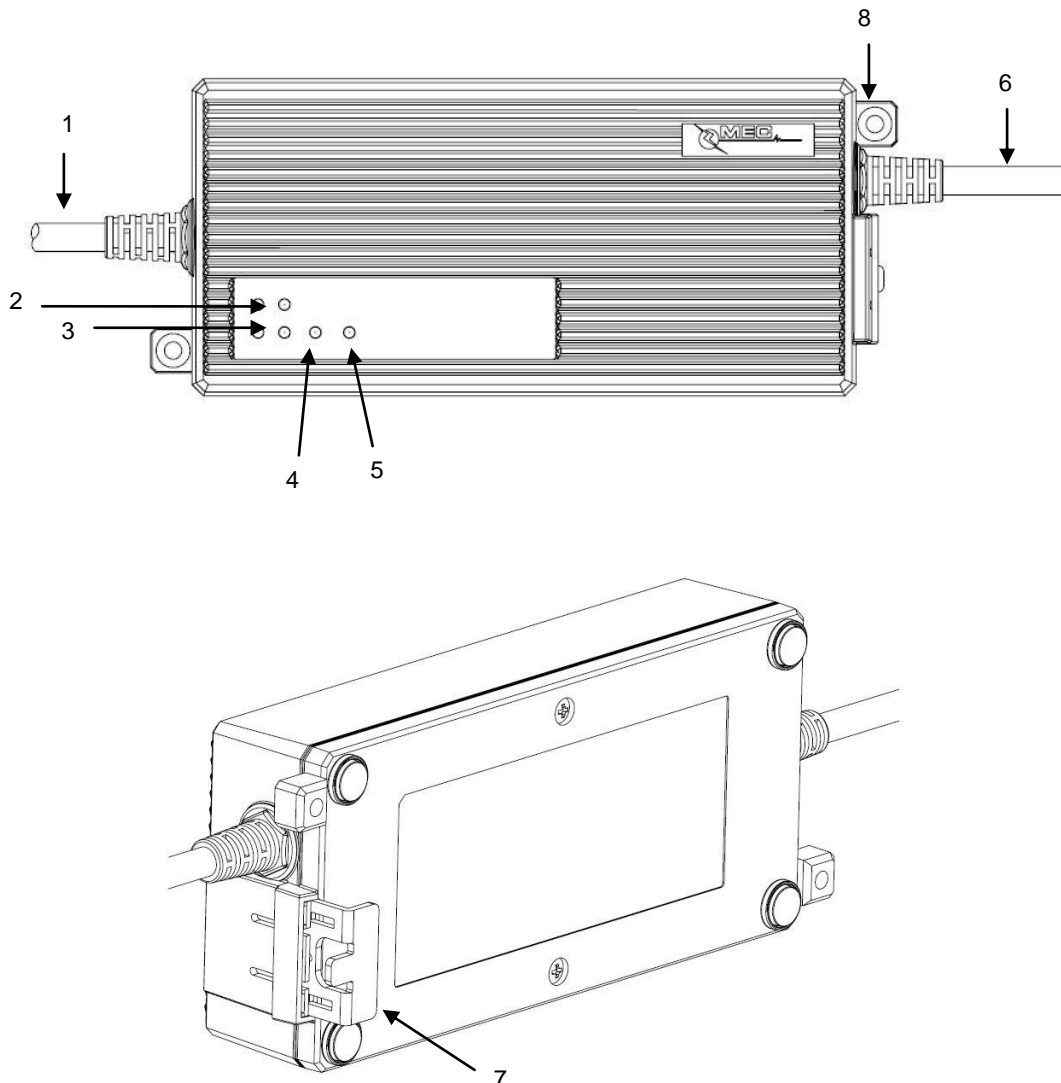

5. Operation

ATTENTION:

- Before operating please make sure that the power cable and the charger including the charging cable show no damages and make sure that the mains supply complies with the specification.
- Please consider the charging instructions from the battery manufacturer before charging.

If you want to connect the charger to the battery, please have a look to the following points:

- Make sure that the device is switched off and disconnected from the mains.
- Connect the terminals to the battery.
- Connect the power cable to the mains supply and switch ON the device.

6. Charging the battery

The charging process starts automatically and runs through the following four charging phases:

1. Charging phase: soft start

This charging step is indicated by **constant lighting of the Charge-LED** (4).

Explanation: During the soft start phase the charger reduces charging current, in order to extend battery lifetime.

2. Charging phase: constant current

This charging step is indicated by **blinking slowly of the Charge-LED** (4).

Explanation: During the constant current phase, the battery is being charged to ~80% of its capacity.

3. Charging phase: constant voltage

This charging step is indicated by **blinking quickly of the Charge-LED** (4).

Explanation: During the constant voltage phase the battery is being charged to its maximum capacity.

After reaching the maximum capacity the **green Full-LED is constantly shining**.

The charger can now be disconnected from the battery or remain connected to the battery (see Auto-restart function).

Auto-restart function

As long as the charger remains connected to the battery, the device will automatically restart the charging process after 30 days or a drop in battery voltage below 3.4V / cell.

Disconnect the charger from the battery

- Switch off the battery charger;
- Disconnect the battery charger from the battery;



When disconnecting the battery from the device during charging process, please disconnect the charger from the mains immediately. A continuation of the charging process is equal to a new charging cycle; all relevant points of the Operating Instructions have to be considered.

After disconnecting the charger from the mains, please **wait at least 5 seconds** until reactivating the device – otherwise this may result in damage.

Battery care:

- Never expose the battery to high temperatures, as this causes permanent battery capacity loss.
- Never deep-discharge or overcharge the battery, cells can be damaged irreversibly.
- If possible, always disconnect the battery from the load when being stored over long periods of time.
- Store battery in a dry and cool place at about 40-60% of its rated capacity.

- Please consider the charging instructions from the battery manufacturer!

7. Errors and Troubleshooting

Table 1: General errors:

Error description	Solution
No LED lighting or blinking after connecting mains	<input type="checkbox"/> Check if charger is connected to mains supply <input type="checkbox"/> Check function of mains supply
Green Mains- LED is on, charger is connected to battery and the charging process don't start	<input type="checkbox"/> Check connection to battery <input type="checkbox"/> Check if battery is damaged or deeply discharged
Error- LED blinking (N x blinking / 2 sec pause)	<input type="checkbox"/> Please see the table below for error description

Table 2: Error- LED blinking signals:

Blinking Signal ¹⁾	Error description
1 x	Battery damaged
2 x	Battery voltage is too high or wrong battery connected
5 x	Charger temperature is too high as charging

¹⁾ Blinking signals in continuous loop.

8. Technical Specifications

Version	4S / 7A
MEC Art.-no.	126-04702-430IS-1720
Charge characteristic	4-Stufen Ladeprofil
Input	100...240VAC / 50-60Hz
AC cable	1.5m ±0.1m CEE 7/16
Charging current max. [A]	7 ±6%
Charging voltage max. [VDC]	14.55±1%
Restart charging voltage [VDC]	13.2
Output power max.	120W
Back current	<1mA
Efficiency	>85% @ 230V
DC-Cable	Length: 1.2m ±0.1m incl. Alligator clips
Indicators	4 LEDs
Cooling	Convection cooled
Operating temperature range	-10°C...40°C
Device protection	Over temperature, reverse polarity, short circuit, over load
Temperature sensor	Internal
Certification	CE
Enclosure	Plastic housing
Protection class	2
IP-code	IP68
Dimensions / Weight	174 x 84 x 45 mm / ~ 850g

9. Advice for Disposal



It is prohibited to dispose the charger into the house- and residual waste removal (WEEE-Richtlinie 2002/96/EG und EAG-VO), it must be disposed at the according collection points. For the protection of our environment please inform yourself at your communal administrative agency about your nearest disposal point.

The charger equates to the RoHS-directive 2002/95/EG, for the restriction of the use of certain hazardous substances in electrical and electronic equipment.



10. Disclaimer of Warranty

- The warranty period (see our GTC) starts with device being dispatched by the manufacturer. The MEC-Energietechnik GmbH is accepting liability by guaranteeing to working hours and spare parts only.
- For damages caused by non-observance of the operating instructions, inappropriate start up or handling as well as reconstructions and modifications of the device, the warranty claim expires and MEC-Energietechnik GmbH assumes no liability for consequential damage to property or persons!